



FSA Guidance on the application of BS9251:2005

INTRODUCTION

This guide is intended to assist suitably trained and qualified fire sprinkler contractors in the interpretation of BS9251:2005, in order that they are better able to install residential/domestic fire sprinkler systems, which are both reliable and cost effective.

The guide is also intended to clarify ambiguous areas of the Standard and to provide much needed guidance on areas not covered in this Standard.

THIS GUIDE IS NOT INTENDED TO REPLACE BS9251 AND USERS OF THIS GUIDE SHOULD ALWAYS REFER TO A FULL COPY OF BS9251:2005.

You are therefore encouraged to purchase a full copy of BS9251:2005 from the British Standards Institute, 389 Chiswick High Road London W4 4AL Telephone +44 (0)20 8996 9000 fax +44 020 8996 7001 email cservices@bsi-global.com. Members of the FSA can obtain a copy from the office at a discount.

It should be noted that BS9251:2005 is a Code of Practice and as such its recommendations are not mandatory. However designers and installers should ensure that where a system deviates from the recommendations in the Standard, these are brought to the attention to the Authority Having Jurisdiction (where applicable) and/or the client for approval.

For ease of reference throughout this document the original wording from the Standard is shown in black and our notes and recommendations are in the box in blue.

This guidance has been approved by the FSA Technical Committee and is based on the practical experience of the members of the Fire Sprinkler Association in the use of DD 251 and BS 9251 over the past six years, and from experience gained in the USA over the past 25 years. This guidance should always be evaluated in the light of the specific circumstances of a particular installation.

The FSA uses the term “residential sprinkler” as a generic term to describe the special type of residential fire sprinklers installed in all kinds of dwellings, whether classed as ‘Domestic’ or ‘Residential’ in BS 9251.

History of Residential Sprinklers

Residential Sprinkler systems were developed in the United States in the mid-1970s in response to the unacceptable levels of fire casualties then being experienced. The first proper residential sprinkler heads reached the market in the early 1980s and since then many millions of systems have been installed, not only in the United States, but also in several other parts of the world.

Experience to date has shown the systems to be extremely reliable and effective with no recorded deaths in protected properties, and 80% reduction in injuries and property damage.

The primary objective of a residential/domestic sprinkler system is to control any fire that occurs to give more time for occupants to escape or be rescued.

BS9251:2005 Sprinkler systems for residential and domestic occupancies – Code of Practice

FORWARD

This British Standard has been prepared by a Task Group from Technical Committee FSH/1812. It supersedes DD 251:2000, which is withdrawn. It gives recommendations for the design, installation, components, water supplies, commissioning and maintenance of fire sprinkler systems for use specifically in residential and domestic occupancies. It is intended for the use of designers, engineers, architects, surveyors, contractors, installers and authorities having jurisdiction. Sprinkler protection for other buildings and industrial plant is specified in BS 5306-2 and BS EN 12845.

Fire sprinkler systems for domestic and residential application are designed to provide an additional degree of protection of life and property, above that already achieved by the installation of smoke and/or fire detectors and systems. This British Standard presumes that the sprinkler protection will form part of an integrated fire safety system as part of the building design.

FSA Commentary & recommendations.

This standard covers a wide range of residential occupancies, from mobile homes through residential care homes to high rise blocks of flats.

Fire sprinklers can provide a level of fire protection that is superior to that recommended by the passive/alarm provisions of the Building Regulations advisory document Approved Document 'B' (ADB). It therefore follows that where a residential sprinkler system is to be installed in accordance with BS9251:2005, it may be possible to relax some recommendations of ADB, the sprinkler protection being regarded as a 'compensatory feature'. In such cases the design should be agreed with the appropriate building control officer or approved inspector BEFORE IMPLIMENTATION.

The use of fire sprinklers can form the basis of a fire-engineered solution to which other form of protection should be added as required. The inclusion of other forms of fire protection should be evaluated by assessing the type of building, occupants and risks involved.

In particular, it is considered that current provisions of fire protection are inadequate for the vulnerable in society who may not be able to make their own escape from a fire. Under these circumstances fire sprinkler will at the very least provide extra time for occupants to make their escape or be rescued.

Smoke alarms should always be provided to complement the fire sprinkler system. This will give warning of slow burning fires that may not produce sufficient heat to trigger the sprinkler system.

Product certification/inspection/testing. Users of this British Standard are advised to consider the desirability of third-party certification/inspection/testing of product conformity with this British Standard. Appropriate conformity attestation arrangements are described in BS EN ISO 9001. Users seeking assistance in identifying appropriate conformity assessment bodies or schemes may ask BSI to forward their enquiries to the relevant association.

Third party certification is recommended, and fire sprinkler contactors should become appropriately accredited. However the FSA does recognise that for installers specialising in individual single-family dwellings such schemes may not always be appropriate.

The recommendations contained in this British Standard result from the best technical information available to the committee at the time of writing.

The standard was drafted when changes in the US approach to the flow rate of second and subsequent operating sprinklers was changing. Hence, particularly with regard to operating pressures and flow rates, information used in the standard is now out of date. Please see guidance in Section 5.2.5 for more information.

Firefighting and life protection encompasses a wide field of endeavour and as such it is impracticable to cover every possible factor or circumstance that might affect implementation of this British Standard. Therefore the design and installation of any system should be entrusted to a suitably qualified and experienced sprinkler contractor.

Suitable training is provided by the FSA, and successful attendance at a course, shown by the gaining of appropriate certificates, meets the qualification requirement. Full details can be obtained for the office or from our web site at www.firesprinklers.info. All training is fully supported by the FSA Technical Department.

Introduction

Sprinkler systems have demonstrated their value in protecting life and property in industrial and commercial applications for many years. The advent of sprinklers that operate at an earlier stage in the development of a fire, plus the recognition that the largest numbers of deaths from fire occur in the home, have led to the introduction of sprinkler systems specifically designed for residential and domestic occupancies.

A correctly designed and installed sprinkler system can detect and control a fire at an early stage of development and activate an alarm. Operation of the system will rapidly reduce the rate of production of heat and smoke, allowing more time for the occupants to escape to safety or be rescued.

In the USA the original, primary intention of these systems was simply to prevent flashover. Flashover is the point in the development of a fire at which the temperature in the compartment is so high that anything not already on fire spontaneously ignites driving the temperature even higher and consuming all the oxygen. If flashover occurs no one in the compartment can survive. Since the early days of residential 'life safety' protection with sprinklers, it has been appreciated that sprinkler systems installed to an appropriate standard will almost certainly prevent life loss elsewhere in the building, outside the room in which the fire starts. In the majority of cases, the lives of those in the room of origin will also be saved.

This British Standard accordingly covers design, installation, components, water supplies, maintenance and testing of residential and domestic sprinkler systems installed for life safety purposes.

Residential and domestic fire sprinkler systems are systems in accordance with this standard and consist of a water supply, backflow prevention valve (check valve), stop valve, priority demand valve (where required), automatic alarm system (both internal and external) and pipework to quick response sprinklers. The sprinklers are fitted at specified locations, the appropriate sprinkler type being used for each location. The main elements of a typical domestic fire sprinkler system are shown in Figure 1a) and Figure 1b), Figure 2a) and Figure 2b) and Figure 3a) and Figure 3b).

Sprinklers operate at a pre-determined temperature to discharge water over a known area below. The flow of water thus initiated causes the sounding of an alarm. Only those sprinklers operate which are individually heated above their operating temperature by the heat from the fire.

The provision of a sprinkler system does not negate the need for other fire precautions or practical measures, which may include structural fire resistance, escape routes, smoke or fire detectors and safe housekeeping practices. Even with the installation of a sprinkler system, normal actions on the discovery of a fire should be taken, such as immediate evacuation and the calling of the fire service. The sprinkler system should be turned off by the fire service when it is deemed safe to do so.

Sprinkler system maintenance is not complex but is essential (see Clause 7). It is important that owners and occupiers pay particular attention to precautions issued by the sprinkler contractor, such as the avoidance of obstructions to the sprinkler, or the painting of the sprinkler head.

Residential Sprinkler systems were developed in the United States in the mid-1970s in response to the unacceptable levels of fire casualties then being experienced. The first proper residential sprinkler heads reached the market in the early 1980s and

since then many millions of systems have been installed, not only in the United States, but also in several other parts of the world.

Experience to date has shown the systems to be extremely reliable and effective with no recorded deaths in protected properties, and 80% reduction in injuries and property damage.

The primary objective of a residential/domestic sprinkler system is to maintain a survivable environment in the room of origin of the fire, in order to give occupants more time to escape or be rescued.

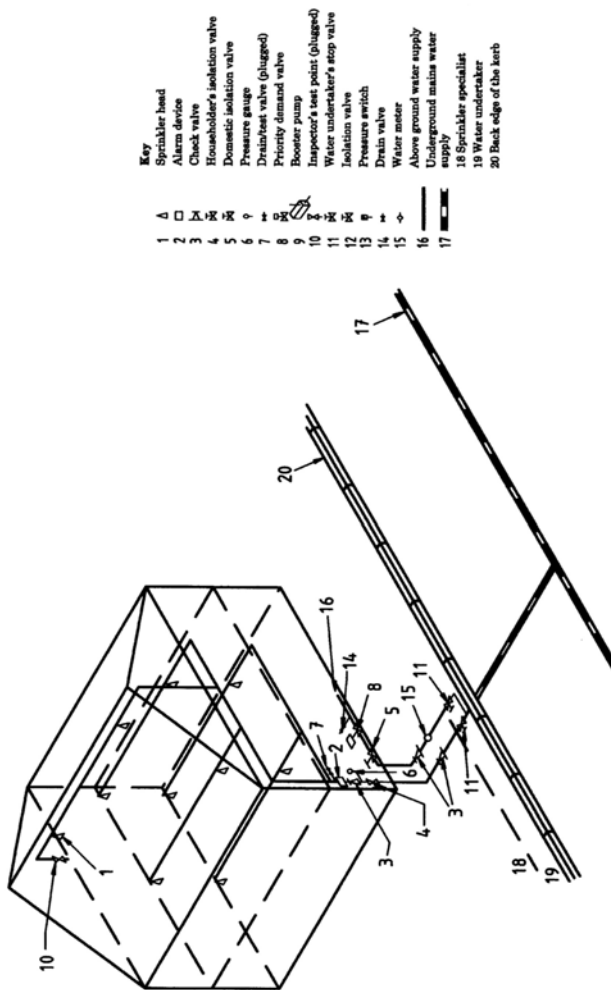

Note 1 Fluid category 2 water supply no additives
 Note 2 Check valve to comply with fluid category 2 no additives

Figure 1b) – Typical mains fed sprinkler system installation control details – for new buildings (metered domestic supply)

Diagrams 1(a) – 3(b) omitted

BS9251:2005 includes several diagrams showing a number of acceptable arrangements for the water supply. These arrangements were agreed with representatives of the Water Industry through Water UK and are featured in the Water Protocol document published by the Fire Protection Association or available from the FSA web site at www.firesprinklers.info under "Publications".

The diagram above shows the preferred type of arrangement. Notice that the incoming service pipe is split before the water meter and the sprinkler supply bypasses the water meter altogether. The intention is that the sprinkler system is not overly restricted by pressure drop through the meter and that any water used is free.

1 Scope

This British Standard gives recommendations for the design, installation, components, water supplies and backflow protection, commissioning, maintenance and testing of fire sprinkler systems installed for life safety purposes with additional benefits for property protection in residential and domestic occupancies.

Residential occupancies, for multiple occupation, not exceeding 20 m in height, include apartments, residential homes, houses of multiple occupancy (HMOs), blocks of flats, boarding houses, aged persons homes, nursing homes, residential rehabilitation accommodation and dormitories.

There is no technical reason why residential sprinklers systems should not be able to provide equal levels of fire protection to domestic or residential occupancies regardless of size or occupancy. See Note in 3.17.

Nevertheless the FSA recommends that in large buildings with more than 1000 sprinkler heads, and where a property exceeds 20m in height, provision for a back-up water supply with dual pumping arrangements should be made.

Domestic occupancies include individual dwelling houses, individual flats, maisonettes and transportable homes.

NOTE Care should be taken particularly when specifying residential sprinkler systems that the fire/fuel loading in any given occupancy does not exceed that which would normally be found in a residential living room, kitchen and bedrooms. If the fire/fuel loading is greater than that of a conventional residential occupancy then consideration should be given to installing a sprinkler installation in accordance with BB 5306-2/BS EN 12846. Key indicators of high fire loading include significant volumes of video tapes, books, paper and institutional catering facilities.

2 Normative references

Text omitted - please refer to BS9251:2005

3 Terms and definitions

For the purposes of this British Standard the following terms and definitions apply.

3.1 alarm device

electrical or mechanical device for detecting water flow into the system and sounding an alarm

Mechanical alarm devices are more suitable for industrial/commercial sprinkler systems and use a significant amount of extra water, and are very rarely appropriate.

The FSA therefore recommends the use of electrical alarm systems, which may be combined with a smoke alarm system, subject to the agreement of the Authority having Jurisdiction (AHJ). (The AHJ will usually be the local authority building Control)

3.2 alarm system

electrical or mechanical system audible internally and externally, with a built-in precaution to avoid spurious alarms

NOTE An electrical system should be mains powered and have a back up battery of adequate capacity.

3.3 alarm test valve

valve through which water may be discharged to test the operation of alarm system

3.4 backflow prevention device

type EA verifiable single check valve which permits water to flow from upstream but not in the reverse direction

Care should be taken to ensure that any backflow device used does not unnecessarily restrict flows. For potable water (Category 2 water), the normal situation, a single check valve is required. Where additives, such as anti-freeze solutions are used, a double check valve is required by the water authorities.

3.5 cistern

stored water supply with cover

NOTE Attention is drawn to the Water Regulations [1], [2], [3] which cover requirements for cisterns.

3.6 concealed sprinkler

recessed sprinkler with a cover plate that disengages when heat is applied.

3.7 domestic occupancy

individual dwelling for occupation as a single family unit used or constructed or adapted to be used wholly or principally for human habitation, such as individual dwelling houses, individual flats, maisonettes and transportable homes, with a maximum individual room size of 40 m²

NOTE In the preparation of this standard it was thought necessary to reconsider areas of sprinkler operation and this will be subject to further investigation.

There is no technical reason to support the introduction of the 40m² limit for individual room size. Of the various versions of residential sprinkler standards around the world, this is the only one to introduce a room size limitation. In the USA, where room sizes often exceed these limits, there have been no reported problems in over 25 years of experience.

3.8 experienced sprinkler contractor

A sprinkler contractor who is suitably qualified and experienced and has independent documentation providing evidence of this

It is recommended that all sprinkler designers and installers are properly trained and that they keep their knowledge up to date by attending refresher courses on a regular basis. As such the FSA provides a comprehensive range of Training Courses details of which can be obtained from the office or our web site at www.firesprinklers.info.

There is a full list of FSA Trained contractors on our web site.

3.9 fire pump

pump that is automatically operated in the event of a fire which supplies water to a sprinkler system from a water storage facility or from a mains supply

For residential sprinkler systems it is not necessary to specify a "fire pump" as defined in BS5306 pt II or BS EN 12845. Pumps, however, should be continuously rated and designed to last at least as long as the sprinkler system (at least 50 years). Pumps for most residential sprinkler systems can be run off a single phase supply.

3.10 fusible link sprinkler

sprinkler which opens when an element provided for that purpose melts

3.11 glass bulb sprinkler

sprinkler which opens when a liquid-filled glass bulb bursts

3.12 pendent sprinkler

sprinkler in which the nozzle directs the water downwards

3.13 priority demand valve

valve for isolating the supply to the domestic service in the event of sprinkler operation

3.14 quick response sprinkler

sprinkler with quick response temperature sensing element which operates to allow water to discharge in accordance with BS EN 12259-1

3.15 recessed sprinkler

sprinkler in which all or part of the heat sensing element is above the lower plane of the ceiling

3.16 residential pattern sprinkler

sprinkler which gives an outward and downward water discharge, suitable for use in domestic and residential occupancy

Only residential pattern sprinklers should be used in habitable parts of the occupancy. Residential pattern sprinklers are available in pendant, concealed, recessed and sidewall configurations.

3.17 residential occupancy

occupancy for multiple occupation not exceeding 20 m in height, with a maximum individual room size of 180 m², such as apartments, residential homes, houses of multiple occupancy (HMOs), blocks of flats, boarding houses, aged persons homes, nursing homes, residential rehabilitation accommodation and dormitories

NOTE 1 Where multiple occupation buildings exceed 20 m in height, special circumstances need to be considered and the authority having jurisdiction should be consulted. This matter is receiving the attention of the relevant BSI committee with a view to issuing an amendment.

There is no technical reason why residential sprinklers should not be able to provide the same benefits regardless of the height of a building. However, because many more people occupy the building the FSA recommends that the system be provided with dual pumps, with independent electrical supplies. See recommendations in Section 1. SCOPE.

NOTE 2 This occupancy classification is not suitable for secure accommodation, asylum centres and large, open, communal dormitories or equivalent hazards.

The FSA sees no reason why residential sprinklers should not provide adequate protection to the types of occupancies listed above.

3.18 room

area, enclosed by walls and a ceiling, which may have openings to an adjoining room or adjoining rooms provided such openings have a lintel depth of at least 200 mm

3.19 service pipe

pipe supplying water from a water supply to any premises that are subject to water pressure from that water supply

The term "service pipe" is usually used to describe the pipe that runs from the water undertakers main to the building.

3.20 sidewall pattern sprinkler

sprinkler which gives an outward half paraboloid pattern of water discharge

3.21 stop valve

manually operated valve for controlling the flow of water into the system pipework which is normally kept in the open position

3.22 subsidiary alternate system

portion of a sprinkler system which is capable of being charged with air or water

3.23 upright sprinkler

sprinkler in which the nozzle directs the water upwards

3.24 wet pipe system

sprinkler system which is designed to be permanently charged with water

4 Consultation

Text omitted - please refer to BS9251:2005

5 Design

5.1 Water supplies

It is recommended that the sprinkler contractor should, wherever possible, act as agent for the customer in negotiations with the water supplier.

In the event of any disputes or disagreements reference should be made to the water protocol document - Guidelines for the Supply of Water to Fire Sprinkler Systems - agreed between the Water and Sprinkler Industries and published by the Fire Protection Association (available for download under "Publications" on our web site at www.firesprinklers.info).

5.1.1 Types of supply

Sprinkler systems should be connected to one of the following water supplies:

- a) a mains water supply;
- b) pressure tank or vessel;
- c) automatic fire pump drawing from a stored water facility;
- d) automatic fire pump drawing water from a mains water supply or an elevated storage cistern;
- e) gravity fed stored water system.

Stored water may include swimming pools, lakes, and wells, so long as a proper survey has been conducted and the sprinkler system designed is satisfied that there is sufficient capacity to provide at least the minimum volume of water and thus time of operation specified in this Standard. Existing water supply arrangements for the domestic supply in high rise buildings are normally adequate for residential sprinkler systems.

5.1.2 Supply characteristics

When planning to use a mains water supply to feed a sprinkler system, prior to installation the minimum mains pressure and capacity should be ascertained in conjunction with the water undertaker.

When using an existing service pipe the pressure should be checked and flow rate ascertained at the point of entry to the building.

The above may not always be practically possible, especially for new properties where the water supply has yet to be installed. Under such circumstances it should be possible to either specify the flow and pressure required so that the Water Supplier may make the appropriate provisions, or to conduct tests on the existing main.

Where it is not possible to check the pressure and flow as required above, then it is essential that a test to the full flow/pressure requirement of the system be conducted prior to the commissioning of the installation. See Section 5.3.3.3.e.

In general, where a water main is in excess of 3 inches in internal diameter, the static pressure can be taken to be the same as the dynamic pressure.

When specifying the size of the service pipe care should be taken to ensure that there are no unnecessary restrictions caused by - the mains tapping, pipe connectors, water meter, water meter housing, backflow prevention devices, or stop cocks.

5.2 Design and installation criteria

5.2.1 System design and installation

The system should be designed and installed by an experienced sprinkler contractor.

In as much as the sprinkler system is a life safety device all personnel should be suitably trained and qualified.

5.2.2 System type

A sprinkler system should be a wet pipe system, ie. one that is permanently charged with water. Precautions should be taken to prevent the water freezing (see 6.1.4).

Residential sprinklers have only been tested and approved of use in wet pipe systems. It is recommended that not more than 500 sprinklers should be fed by a single valve arrangement.

5.2.3 Extent of sprinkler protection

Sprinkler protection should be provided in all parts of the dwelling, with the permitted exception of:

- ▶ bathrooms with a floor area of less than 5 m²;
- ▶ cupboards and pantries with a floor area of less than 2 m² and where the least dimension does not exceed 1 m and the walls and ceilings are covered with non-combustible or limited-combustible materials;
- ▶ non communicating, attached buildings such as garages, boiler houses, etc.;
- ▶ crawl spaces.

NOTE 1 "Non communicating" means separated from the protected premises by a 30 min fire resisting construction in accordance with BS 476 or equivalent European Standard.

NOTE 2 Certain authorities may require 60 min fire resisting construction.

NOTE 3 Lift shafts are not excluded from protection.

Loft spaces were a permitted exception under DD251:2000 in domestic occupancies provided that the area was not used for storage and permission was obtained from the authority having jurisdiction (AHJ). There have been no recorded deaths from fires started in lofts since 1945. Attics are a permitted exception in NFPA 13D and 13R where they are not used or intended for living purposes or storage.

If lofts and attics are to be protected by the sprinkler system then attic type sprinklers, other suitable sprinklers or attic sprinkler systems should be specified because the roof slopes very often exceed the maximum -permitted slopes for residential type sprinklers.

5.2.4 Hydraulic calculations

Calculation of pressure losses in pipework should be carried out in accordance with Annex A to determine the recommended pipe sizes to meet the performance recommendations in 5.2.5 with the water pressure and flow rate at the lowest flow/pressure characteristics anticipated. Where systems are to be directly mains fed, the size of service pipe to the premises that will feed the sprinkler system should be agreed with the water supplier.

Care should be taken to ensure that the losses in the valve arrangements are taken into account in the calculations.

5.2.5 System flow rate

5.2.5.1 Sprinkler flow rates

A sprinkler system should be capable of providing flow rates at the sprinklers of not less than:

- a) for domestic occupancies:
 - 1) 60 l/min through any single sprinkler; or
 - 2) 42 l/min through each of two sprinklers operating simultaneously in a single room;
- b) for residential occupancies:
 - 1) 60 l/min through any single sprinkler; or
 - 2) 42 l/min for each sprinkler operating simultaneously up to a maximum of four sprinklers in a single room.

Flow rates must be related to area coverage per sprinkler, which for the rates above is 15m², and is addressed later, see clause 5.2.9.2. Over the past few years the

minimum flow rates of residential sprinklers have been the subject of considerable research in the USA. As a result a minimum application density of 2.02 mm/min has been adopted. This has had little impact on single sprinkler being used over small areas. However it has had a significant effect on flow requirements for the second and subsequent sprinklers, and for sprinklers used at extended coverage areas (as is approved for use in the USA and elsewhere).

Whilst until July 2003 US listing practice allowed the 2nd sprinkler to operate at a lower flow rate than the first sprinkler, since that time the second and subsequent operating sprinklers have been required to operate at the same flow rate as the first. There are now no UL Listed sprinklers with accepted flow rates as low as 42l/min over 15m².

Sprinklers should be used in accordance with their approval listed discharge performance.

5.2.5.2 Residential pattern sprinklers

Where residential pattern sprinklers are used in domestic occupancies, the system should be capable of providing flow rates to permit one or two sprinklers to operate simultaneously at not less than the flow rates given in 5.2.5.1a) or their approval listed discharge performance, whichever is the greater, plus any flow for alarm purposes (see 5.3.3).

Where residential pattern sprinklers are used in residential occupancies, the system should be capable of providing flow rates to permit up to four sprinklers to operate simultaneously at not less than the flow rates given in 5.2.5.1b) or their approval listed discharge requirements, whichever is the greater, plus any flow for alarm purposes (see 5.3.3).

Only residential sprinklers should be used in the habitable parts of the dwelling. If the attic or other uninhabitable areas are to be protected other types of sprinkler are acceptable. For instance special attic sprinklers may be used in attics.

5.2.5.3 Minimum operating pressure

The minimum operating pressure at any sprinkler should not be less than 0.5 bar.

This recommendation is not related to hydraulic factors. It is to ensure release of the sprinkler valve at any time in the life of the system.

5.2.6 Flow rate requirements for mains water supply connections

Where the mains water supply connection serves only the sprinkler system, the system should be capable of providing flow rates at the sprinkler heads in accordance with the recommendations of 5.2.5.1

Where the mains water supply connection serves both the sprinkler system and the domestic or residential occupancy supply, the sprinkler system should be capable of providing flow rates at the sprinkler heads in accordance with the recommendations of 5.2.5 by:

- a) the operation of an automatic priority demand valve; or
- b) for domestic occupancies, the flow rate recommended in 5.2.5.1 plus at least 25l/min;
- c) for residential occupancies, the flow rate recommended in 5.2.5.1 plus the design demand for the residency but not less than 50 l/min.

When relying only on a direct mains water supply only 85 % of the water pressure and flow rates at the lowest flow/pressure characteristics anticipated should be allowed in the calculations.

Available flow rates and pressures should have been assessed at the times of highest demand, where the pressure/flow to the sprinkler system is at its lowest. The 85% limitation is excessive, but does give an allowance for the possibility that water pressure may be reduced at some point in the future.

Where the connection to the mains water supply serves more than one dwelling, the system should be capable of providing the flow rates at the sprinkler heads in accordance with the recommendations of 5.2.5.1 at times of simultaneous peak demand from all of the dwellings concerned.

5.2.7 Stored water capacity

Where a water storage cistern is used for both sprinkler and domestic purposes, the stored volume should be at least 110 % of that recommended for the sprinkler system and the domestic connection should be taken above the level of stored water calculated for the sprinkler system and for:

a) domestic occupancies should be calculated on the basis of maintaining actual pressures and flows for 10 min to whichever is the greater of:

- 1) single operating sprinkler situated in the hydraulically most favourable position;
- 2) a pair of operating sprinklers in a single room situated in the hydraulically most favourable position;

b) residential occupancies should be calculated on the basis of maintaining actual pressures and flows for 30 min to whichever is the greatest of: any combination of up to the maximum design number of sprinklers (not greater than four in number), operating in a single room, situated in the hydraulically most favourable position.

In some circumstances, longer times may be needed for escape or rescue of occupants. For instance, it will take longer for fire fighters to reach apartments on the upper floors of taller buildings than maisonettes and to evacuate the building if necessary. Residents in care homes for instance may be unable to make their own escape and therefore any fire may need to be controlled for longer whilst they are being rescued. In other cases, shorter times may be acceptable. Any variations to the times given above should be agreed with the AHJ.

Where the cistern provides a totally dedicated water supply for sprinklers, a low level alarm should be provided and the amount of stored water can be calculated allowing for the proven rate of infill from the water main providing the reduced amount of stored water, should be at least 60 % of the amount calculated without infill.

5.2.8 Fire pump

Where a pump is used to ensure the recommendations of 5.2.5 are met it should be:

- a) located such that it is unlikely to be affected by a fire;
- b) located where the temperature will be maintained above freezing;
- c) protected electrically by suitable fusing;
- d) protected against the effects of fire;
- e) of sufficient capacity to ensure the recommendations of 5.2.5 are met;
- f) suitably designed and manufactured such that testing is needed at not more than annual intervals;

operated automatically on demand and require manual shut down.

The pump should be started periodically to ensure that internal seals do not seize or that corrosion or build up of matter within the pump does not affect its operation. This should be done automatically at intervals of not more than 60 days. Pumps are available with automatic start facilities to meet this recommendation.

5.2.9 Sprinkler coverage and location

5.2.9.1 General

Sprinklers should be installed in accordance with the supplier's instructions but not contravene the recommendations of this standard.

5.2.9.2 Sprinkler spacing

The maximum area protected by each sprinkler should be in accordance with its approved listing performance or 15 m², whichever is the lesser, and sprinklers should not be more than 4 m apart nor more than 2 m from any wall or partition. The distance between sprinklers within a room should not be less than 2 m.

Sprinklers are approval listed according to the UL 1626 fire test requirements for a range of areas of coverage. For each sprinkler type these are displayed in tabular

form. The tested areas range from 13.4m² to 30m², and for some sprinklers to 37m². As the coverage area of a sprinkler increases the required flow rate also increases. This approach allows better application of sprinklers in many properties. This approach is recommended, provided that it is acceptable to the Authority having jurisdiction.

All sprinklers should be installed in accordance with their listed performance for flow rate and spacing, and the distance between sprinklers should not exceed half the listed design spacing from any wall and the distance between sprinklers should not be less than 2.4 m.

5.2.9.3 Sprinkler positioning

Sprinklers should be positioned in accordance with the following recommendations.

- a) Pendent and upright, residential and domestic sprinklers should have heat sensitive elements below the ceiling but not more than 100 mm below the ceiling.
- b) Sidewall sprinklers should have heat sensitive elements within 100 mm to 150 mm below the ceiling.
- c) The heat sensitive elements of recessed and concealed residential sprinklers should be positioned in accordance with the supplier's instructions.
- d) The whole of the floor area and the walls from the floor up to 0.7 m below the ceiling should be wetted when the sprinklers are operated.
- e) For sloping ceilings sprinklers should be positioned in accordance with the supplier's instructions.
- f) The sensitivity and discharge pattern of sprinklers should not be adversely affected by obstructions such as constructional beams or light fittings or other sprinkler heads.
- g) The potential for a shielded fire to develop should be taken into account.
- h) Sprinklers are not less than 50 mm from any wall or partition.

NOTE Concealed and recessed sprinklers may be used with the approval of the authority having jurisdiction.

Concealed and recessed sprinklers have now been tested in the UK and shown to have similar response characteristics to pendent residential sprinklers and so there should be no restriction to their use.

5.3 Components

5.3.1 Sprinklers

5.3.1.1 General

Sprinklers should be of pendent, upright, sidewall, recessed or concealed types, suitable for service in residential and domestic application.

Sprinklers should have a quick response thermal sensitivity rating and be in accordance with DD 252. Only new equipment should be used. Any sprinkler head removed from a system should be discarded.

ALL sprinklers used within the habitable areas of the building should be of "RESIDENTIAL" type.

Currently no sprinklers have been tested in accordance with DD252. In the meantime, sprinklers approval listed to U 1626 or another internationally recognized standard should be used.

5.3.1.2 Size of sprinklers

Text omitted - please refer to BS9251:2005.

5.3.1.3 Temperature rating of sprinklers

Fusible link sprinklers should be colour coded on the frame or sprinkler body; glass bulb sprinklers should be colour coded by the bulb liquid in accordance with BS EN 12259-1.

The temperature rating of the sprinklers should be:

- a) the closest to but at least 20 °C greater than the highest anticipated ambient temperature of the location;
- b) within the range of 79 °C to 100 °C when installed under glazed roofs.

NOTE For normal conditions in the United Kingdom, the sprinkler temperature ratings will be 57°C or 68 °C.

The FSA believes that sprinklers for use in the UK should be rated at the lower temperature of 57°C (where available) in order to better respond to slow developing fires.

5.3.2 Pipes and fittings

Text omitted - please refer to BS9251:2005

5.3.3 Valves and alarm devices

5.3.3.1 General

Text omitted - please refer to BS9251:2005

5.3.3.2 Alarm devices

The system should have one of the following alarm devices, which should be triggered by the flow of water to at least one sprinkler:

an electrically operated flow switch connected to an audible alarm;

a mechanically driven alarm taking the flow into account in the hydraulic calculations. or

The system should have:

- a) at least one internal audible alarm which can be easily heard in all parts of the building or dwelling, as appropriate; and
- b) an audio-visual alarm positioned externally in a prominent position and clearly labelled "FIRE ALARM".

NOTE Means of escape criteria in flats and maisonettes is normally based on a defend in situ criteria and the alarm arrangements should be in accordance with the authority having jurisdiction.

If the property already has an integrated hard-wired smoke alarm or fire detection system, this may be used instead of a dedicated sprinkler alarm, provided that this arrangement is agreed with by the AHJ.

5.3.3.3 Valves

The system should have the following (see Figure 4):

- a) an appropriate back-flow prevention device to prevent mains water contamination;
- b) a stop valve, of the full bore lever type to isolate sprinkler pipework from mains water supply;

NOTE 1 The valve should be locked in the open position to prevent accidental interruption of the water supply to the sprinkler system.

It is essential that the sprinkler shut off valve is clearly marked as such, and that the system cannot be accidentally (or deliberately) turned off. It therefore very important that it is made difficult to access the main shut-off valve and that it is obvious if the system is left turned off.

A means of achieving this is to install the main shut-off valve inside a locked cabinet in such a manner that it is impossible to close the door if the valve is in the closed position.

The location of the sprinkler stop valve should be clearly indicated, especially in larger buildings.

- c) where appropriate, a priority demand valve;
- d) an alarm test valve;

NOTE 2 A test facility should be provided at the end of the hydraulically most remote range pipe on the system consisting of not less than a 22 mm nominal diameter pipe and quick acting test valve with an outlet nozzle equivalent in size to the smallest sprinkler in the system.

This test facility is actually a hang over from LPC Technical Bulletin 14, and found to be an impractical feature, rarely installed, and it is recommended that the flow test is conducted at the drain and test point (e) below.

e) a quick-acting drain and test valve facility fitted at the lowest point of the sprinkler pipework to allow functional testing and the complete draining of the sprinkler system, suitably sized to check the appropriate maximum flow rate specified in 5.2.5, but not less than a 22 mm nominal diameter pipe size.

The move from testing at point d) to point e) has led to other difficulties. When the pressure/flow to the premises has been measured to ensure that it is above the minimum (Clause 5.1.2) then it is sufficient to check the flow through a single sprinkler orifice, equal to the smallest sprinkler in the system. Where the supply to the system has not been proved, then the pipes and orifices need to be adequately sized so that the flow and pressure can be measured to ensure that it is equal to or above the system maximum design requirement. When proving the flow rate of the system allowance should be made for the hydraulic losses between the drain and test point and the most remote sprinkler. (see C & R at 5.1.2)

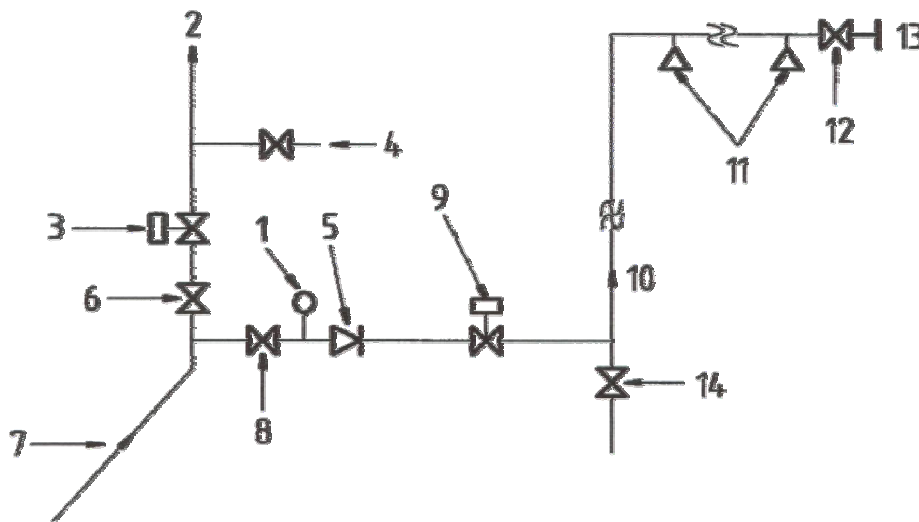

Key I

- | | |
|------------------------------------|---|
| 1 Pressure gauge | 2 To domestic drop off points |
| 3 Priority demand valve (optional) | 4 Drain valve |
| 5 Backflow prevention device | 6 Stop valve |
| 7 Incoming cold water main | 8 Lever operated fullway stop valve |
| 9 Alarm device ^a | 10 To sprinklers |
| 11 Sprinkler heads | 12 Lever operated fullway alarm test valve |
| 13 Plug | 14 Combined drain and alarm test valve ^b |

^aAlarm device with 12+25 s delay to prevent false alarms due to surge.

^b Can be separate.

Figure 4 - Typical sprinkler connection, installation control and monitoring details

5.3.4 Electrically operated devices

Text omitted - please refer to BS9251:2005

6.1 Installation

6.1.1 General

Text omitted - please refer to BS9251:2005

6.1.2 Feasibility

Before installation begins, the service pipe water supply should be tested to ensure that, when at its lowest hydraulic characteristic, the recommended flow rate and pressure can be

achieved. If the recommended pressure and flow rate is not achieved the installation should not proceed and the designer should be consulted.

The above may not always be practically possible, especially for new properties where the water supply has yet to be installed. Under such circumstances it should be possible to either specify the flow and pressure required so that the Water Supplier may make the appropriate provisions, or to conduct tests on the existing main.

In general, where a water main is in excess of 3 inches in internal diameter, the static pressure can be taken to be the same as the dynamic pressure.

See recommendations in Section 5.1.2.

When specifying the size of the service pipe care should be taken to ensure that there are no unnecessary restrictions caused by – the mains tapping, pipe connectors, water meter, water meter housing, backflow prevention devices, or stop cocks.

6.1.3 Pipework

6.1.3.1 Pipe sizes

Pipe sizes should be determined by hydraulic calculations (see Annex A).

6.1.3.2 Pipework support (see Annex B)

Text omitted - please refer to BS9251:2005

6.1.3.3 Pipework through structural timbers

Structural timbers should not be notched or bored in such a way that the integrity of the structure is compromised [see Building Regulations 2000 (applicable to England and Wales)] [6], the Technical Standards Scotland 1990 [7] and the Building Regulations (Northern Ireland) 2000 [8] and BS 6700.

Special care should be taken when notching joists in order not to breach the Building Regulations, especially when using plastic pipe. The Regulation limit the size of a notch to 0.15 x depth of joist ie 37.5mm on a 250mm joist. One inch Blazemaster has an outside diameter of 32mm. Failure to observe these limits has resulted in contractors being obliged to replace joists.

6.1.4 Frost protection (see 5.2.2)

It is essential that any water filled pipework which may be subjected to low temperatures should be protected against freezing at all times.

NOTE 1 Electrical trace heating and/or lagging or antifreeze solutions may be used.

NOTE 2 Water Regulations [1], [2], (3) forbid the employment of anti-freeze solutions where the system is directly connected to a mains water supply.

NOTE 3 Plastics pipe and fittings may be protected using glycerin based anti-freeze solutions. Glycol based anti-freeze solutions should not be used in plastic systems.

Installers and designer should bear in mind that, unlike domestic water pipes, sprinkler pipes have no flow in them whatsoever and so normal lagging may be insufficient to prevent freezing during prolonged periods of sub-zero weather.

Sprinkler pipework should therefore, whenever possible, always be installed within the heated envelope of the dwelling.

LPC Technical Bulletin 211 states that no anti-freeze solutions should be used with CPVC pipe.

It should be noted that Glycerine based anti-freeze is difficult to obtain in the UK.

6.2 Commissioning

6.2.1 Leakage testing

Text omitted - please refer to BS9251:2005

6.2.2 Hydraulic test

The sprinkler system should be tested to ensure that at least the flow rate specified in 5.2.5 can be achieved at the required pressure at the alarm test valve [see 5.3.3.3d)]. If this flow rate at the required pressure cannot be achieved, the system should not be approved for use until the system has been corrected and the test given in this clause has been passed. The installer and the designer should correct the system.

The flow test should be conducted through the drain and test point labelled 14 in figure 4. If required the system designer can calculate the pressure/flow rate required at this point that would indicate that the pressure/flow rate available to the most remote sprinkler would correspond with the manufacturer's specification. See C&R, 5.3.3 e).

6.2.3 Alarm test

The alarm (and/or repeaters) should be heard in all habitable rooms in the premises protected by sprinklers coupled to the alarm device being tested, subject to the recommendations of 5.3.3.2. The stated audibility should be achieved when there is a water flow of not more than 60 l/min through the alarm device under test.

Most residential/domestic systems will use an electric alarm system and these will function at flow rates considerable below 60l/min.

6.2.4 Compliance

On satisfactory completion of the commissioning tests by the experienced sprinkler contractor a certificate should be issued in accordance with 6.3.2b).

This is a key requirement of the Standard. The Certificate, which must be supplied by the sprinkler contractor, confirms that the system has been installed in accordance with the recommendations of BS 9251. Any deviations from that Standard should be agreed with the AHJ, and recorded on the certificate. Copies should be sought by the and provided to the AHJ. It is helpful for the actual water pressure and flows measured on the commissioning test to be recorded on the Certificate.

6.3 Documentation

6.3.1 Presentation

Text omitted - please refer to BS9251:2005

6.3.2 Documents

Text omitted - please refer to BS9251:2005

The owner or occupier should also be supplied with spare sprinkler heads of the same design as those used in the system together with an appropriate tool for fitting them. In the event that replacement of a head is required these spare heads should not be fitted by the owner or occupier but should be fitted by a suitably qualified and experienced sprinkler contractor.

There are reservations on the provision of spare sprinkler heads to householders. It is thought better that they are retained by the contractor conducting maintenance on the system, who would be called in the event that the system operated.

7 Maintenance

7.1 Responsibility

The system should be inspected and tested in accordance with 7.2.

In the normal course of events sprinkler systems are remarkably robust and will withstand lack of maintenance for a considerable period. However this is far from ideal and the maintenance schedule should be conducted at least once a year.

In many cases the main problem for maintenance is access to the property. Where the property is owned by a Housing Association or the like access can usually be arranged to coincide with the annual gas inspection or similar.

7.2 Inspecting and testing

Text omitted - please refer to BS9251:2005

7.3 Log Book

The Log Book referred to in 6.3.2h) should be completed giving details of:

- a) the date of inspection;
- b) details of all tests conducted and their results;
- c) confirmation or otherwise of the sprinkler systems operational status;
- d) confirmation or otherwise of the alarm systems operational status; e) details of any recommendations or comments.

The FSA produces a sample log book for members which includes a guide to residential sprinkles for the end user. The log book also provides space for a service record for up to 50 years.

Table B3 should read -

Table B3 Maximum spacing of fixings for CPVC pipework-

Nominal diameter mm	Horizontal run m	Vertical run m
20	1.7	3.0
25	1.8	3.0
32	2.0	3.0
40	2.1	3.0
50	2.4	3.0
65	2.7	3.0
80	3.0	3.0

This document has been prepared by the Fire Sprinkler Association and approved for distribution by its Technical Committee.

The recommendations contained herein are based on practical experience and technical knowledge of the authors. Users of this guide are therefore advised to consider the advice given carefully before applying it. In any event all deviations from the Standard should be agreed with the Authority Having Jurisdiction (AHJ) before implementation. Should you have any queries concerning this Guide please refer them to the FSA's technical department on 0118-971-2322 or email info@firesprinklers.info.

The FSA cannot take responsibility for these recommendations, which are given in good faith.

The FSA Technical Committee includes-

Roy Young (Chairman), Phil Barnett (Barnett Consultancy), Malcolm Black (Nimbus Fire Systems), Chris Gill (Viking SA), Ian Grist (DIS Sprinklers), Graham Orme (FIRAS), Les Walker (Freelance Associates), Paul Winnett (ITT Lowara Pumps).